



SAFETY IN HUMAN-ROBOT INTERACTION

S. Haddadin, A. Albu-Schäffer and G. Hirzinger

Institute of Robotics and Mechatronics, German Aerospace Center (DLR), Oberpfaffenhofen, Germany



- Abstract -

Physical human-robot interaction and cooperation has become a topic of increasing importance and of major focus in robotics research. Industrial and domestic applications unifying the workspace of humans and robots are foreseeable in the close future and will require safe and dependable robot design and control. An essential requirement to a robot designed for high mobility and direct interaction with human users or uncertain environments is that it must in no case pose a threat to the human user.



- Crash-testing in Robotics -

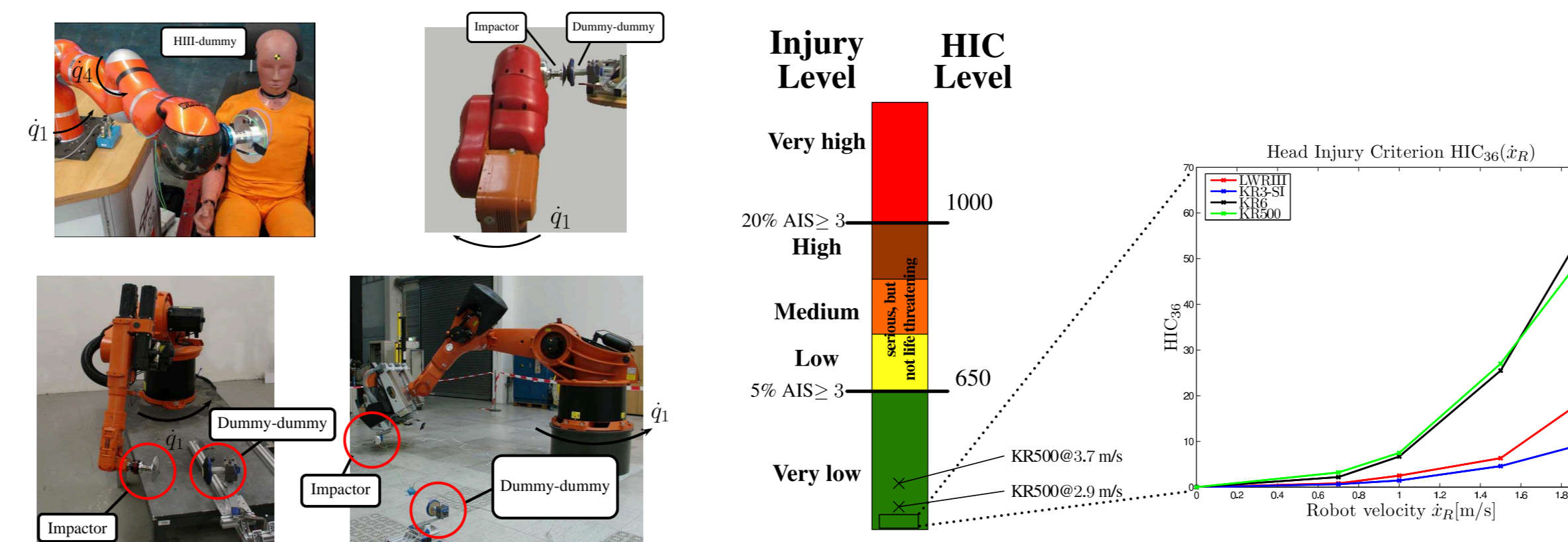

Unconstrained blunt impacts

Intuition: *heavy* \equiv *dangerous* does not apply
 Analogy: running against a wall with 2m/s (\equiv 7.2km/h)
 Low severity injuries as fractures are possible at high robot velocities

Constrained blunt impacts

Intuition: *heavy* \equiv *dangerous* applies now!
 As confirmed by published biomechanical injury data

- Soft-tissue Injury -

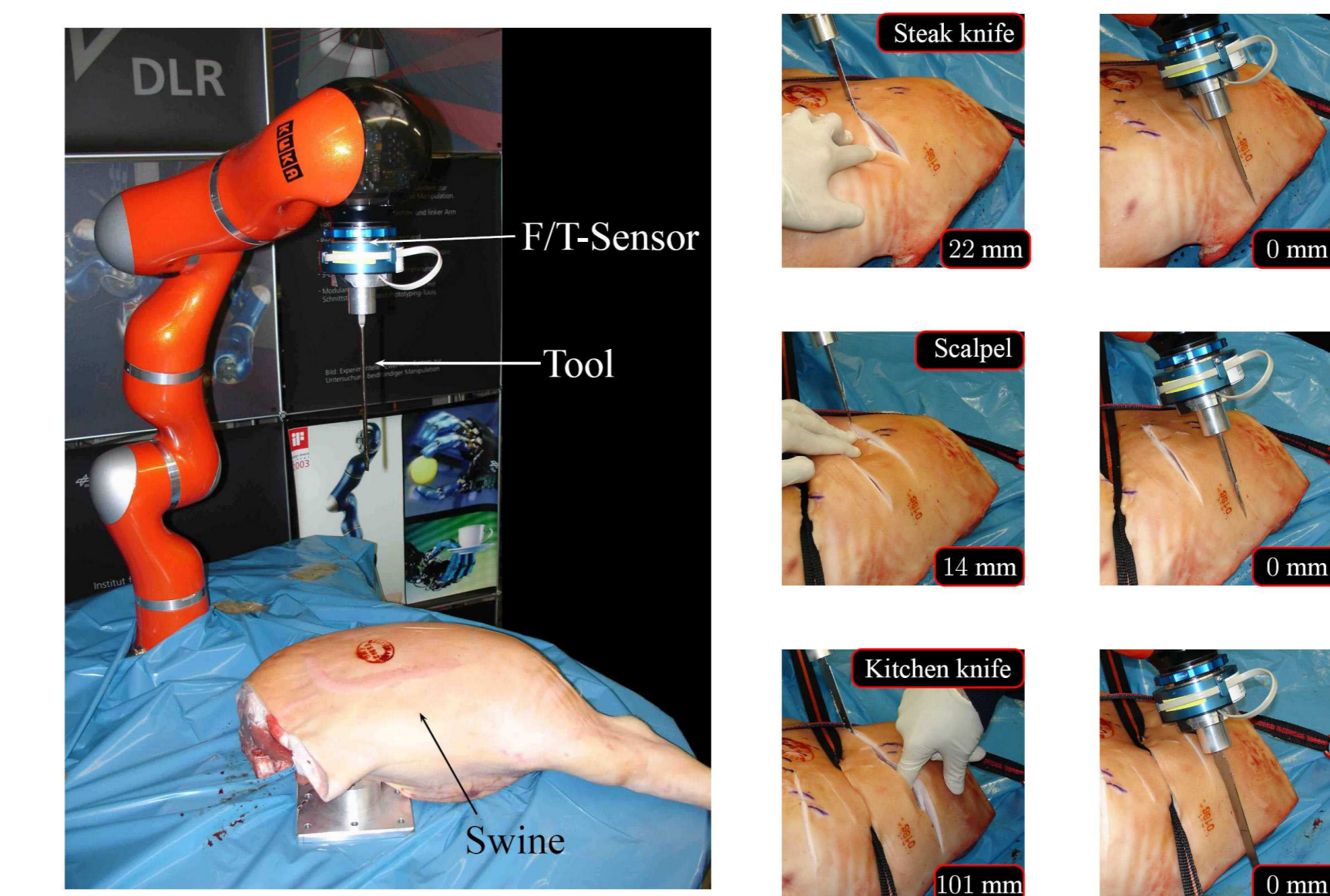

Experimental evaluation of soft-tissue injuries in robotics
 Verification of possible countermeasures by means of control
 Robots will use sharp tools in human proximity
 Focus on stab and puncture wounds due to their lethality

- Synopsis -

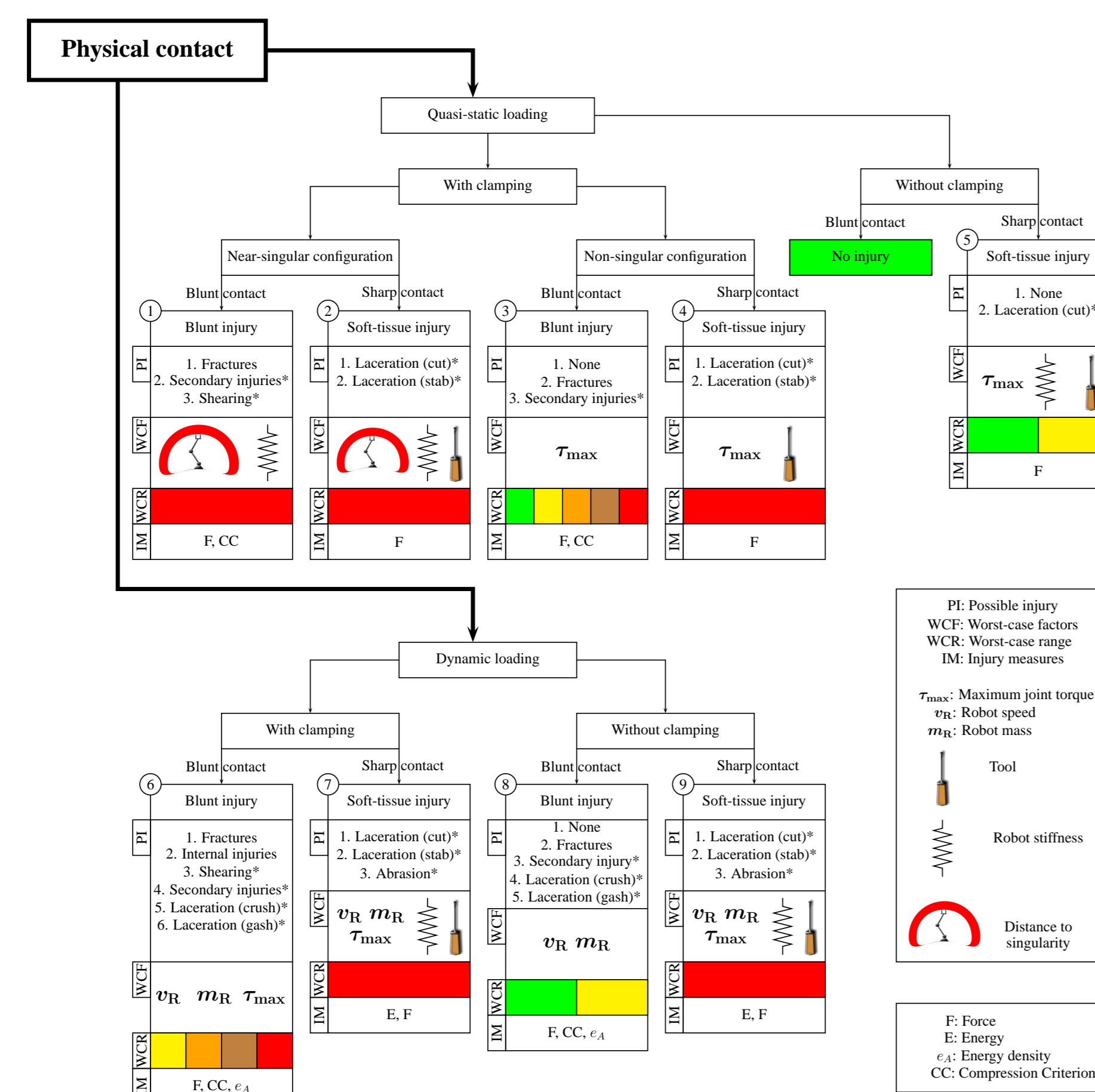

- Collision Detection and Reaction -

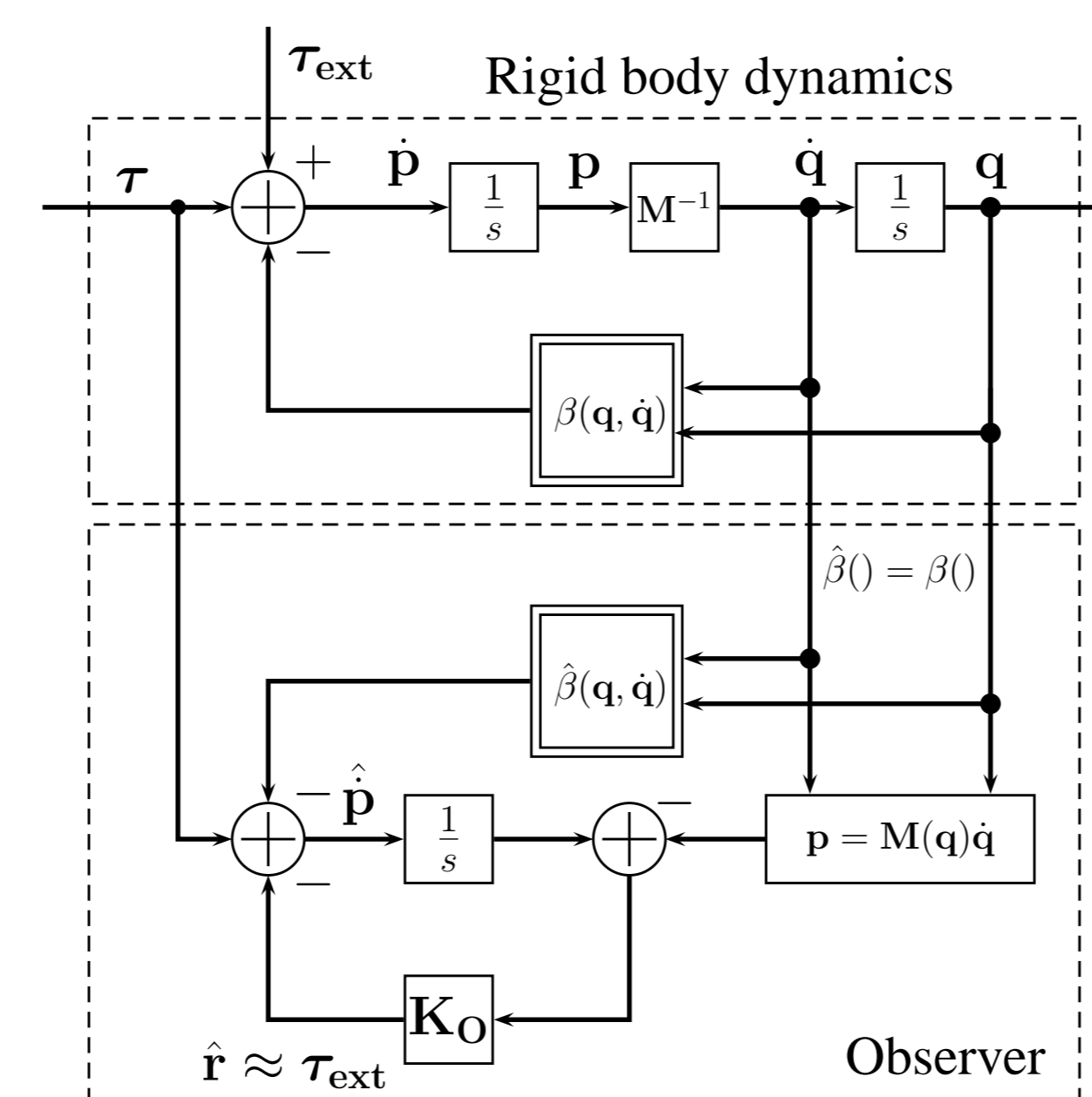

Gives the possibility to distinguish between

nominal condition: desired physical interaction with the robot
fault condition: undesired collisions, possibly causing injuries

- Bibliography -

- [1] Alessandro De Luca, Alin Albu-Schäffer, Sami Haddadin, and Gerd Hirzinger. Collision Detection and Safe Reaction with the DLR-III Lightweight Manipulator Arm. *IEEE/RSJ Int. Conf. on Intelligent Robots and Systems (IROS2006)*, pages 1623–1630, 2006.
- [2] Sami Haddadin, Alin Albu-Schäffer, Alessandro De Luca, and Gerd Hirzinger. Collision Detection & Reaction: A Contribution to Safe Physical Human-Robot Interaction. In *accepted at: IEEE/RSJ Int. Conf. on Intelligent Robots and Systems (IROS2008), Nice, France, 2008*.
- [3] Sami Haddadin, Alin Albu-Schäffer, Alessandro De Luca, and Gerd Hirzinger. Evaluation of Collision Detection and Reaction for a Human-Friendly Robot on Biological Tissues. In *IARP International Workshop on Technical challenges and for dependable robots in Human environments (IARP2008), Pasadena, USA, 2008*.
- [4] Sami Haddadin, Alin Albu-Schäffer, and Gerd Hirzinger. Safe Physical Human-Robot Interaction: Measurements, Analysis & New Insights. In *International Symposium on Robotics Research (ISRR2007), Hiroshima, Japan, 2007*.
- [5] Sami Haddadin, Alin Albu-Schäffer, and Gerd Hirzinger. Safety Evaluation of Physical Human-Robot Interaction via Crash-Testing. *Robotics: Science and Systems Conference (RSS2007)*, 2007.
- [6] Sami Haddadin, Alin Albu-Schäffer, and Gerd Hirzinger. The Role of the Robot Mass and Velocity in Physical Human-Robot Interaction - Part I: Unconstrained Blunt Impacts. In *IEEE International Conference on Robotics and Automation (ICRA2008), Pasadena, USA, 2008*.
- [7] Sami Haddadin, Alin Albu-Schäffer, and Gerd Hirzinger. The Role of the Robot Mass and Velocity in Physical Human-Robot Interaction - Part II: Constrained Blunt Impacts. *IEEE Int. Conf. on Robotics and Automation (ICRA2008), Pasadena, USA, 2008*.