

Virtual Physics Equation-Based Modeling

TUM, October 18, 2022

Equation-based modeling: first steps

equation

```
sx0 = cos(frame_a.phi)*sx_norm + ...  
sy0 = -sin(frame_a.phi)*sx_norm + ...  
vy = der(frame_a.y);  
w_roll = der(flange_a.phi);  
v_long = vx*sx0 + vy*sy0;  
v_lat = -vx*sy0 + vy*sx0;  
v_slip_lat = v_lat - 0;  
v_slip_long = v_long - R*w_roll;  
  
v_slip = sqrt(v_slip_long^2 + ...  
-f_long*R = flange_a.tau;  
frame_a.t = 0;  
f = N*. S_Func(vAdhesion,vSlide,...  
f_long =f*v_slip_long/v_slip;  
f_lat =f*v_slip_lat/v_slip;  
f_long = frame_a.fx*sx0 + ...  
f_lat = -frame_a.fx*sy0 + ...
```

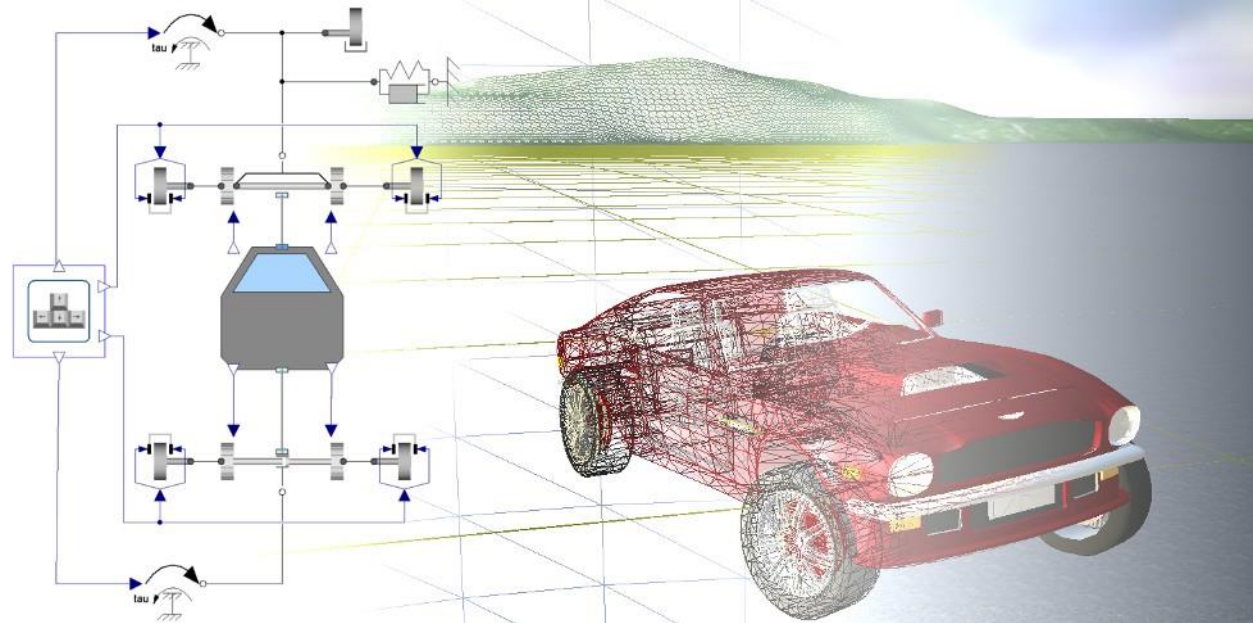

Dr. Dirk Zimmer

German Aerospace Center (DLR), Robotics and Mechatronics Centre

- Let us start with a simple modeling example:
Let us brew beer! (or ferment wine.. for the non-ba(rb/v)arians)
- In this example, we are going to model the fermentation of sugar into alcohol and the corresponding growth and decay of yeast.
- In the process of fermentation each molecule of sugar is transformed into two molecules of alcohol (plus 2 CO₂)

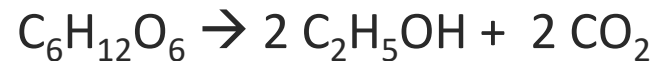

- These are our model variables:
 - Population of yeast: p
 - Birth-Rate: b
 - Death-Rate: d

 - Concentration of sugar: s
 - Concentration of alcohol: a
 - Consumption of sugar: f

 - Current Temperature: T
- These are our model parameters:
 - Volume of vessel: $V = 1$
 - Initial concentration of sugar: $s_0 = 0.2$
 - Initial population of yeast: $p_0 = 0.001$

 - Feeding-Rate Coefficient: C_f
 - Reproductivity: R
 - Sensitivity to poison: S
 - Reference Temperature: T_{ref}

Let us start with the algebraic equations:

- The consumption of sugar (f) is proportional to concentration of sugar (s) multiplied by the population of yeast (p). The proportionality is determined by the feeding-rate (C_f) and the temperature (T)

$$f = s \cdot p \cdot C_f \cdot (T/T_{\text{ref}})$$

- Roughly half of the molecular mass of the sugar is transformed into alcohol, but alcohol has a much lower density. Hence we make the (incorrect) simplifying assumption:

$$a = s_0 - s$$

with s_0 being s at $t=0$

Let us continue with the algebraic equations:

- The Birth-Rate is proportional to concentration of sugar (s). The proportionality is determined by the reproduction (R):

$$b = R \cdot s$$

- The Death-Rate is dependent on the level of poisonous alcohol (a) and the sensitive (S) of the yeast.

$$d = S \cdot a$$

The algebraic equations are:

$$f = s \cdot p \cdot C_f \cdot (T/T_{\text{ref}})$$

$$a = s_0 - s$$

$$b = R \cdot s$$

$$d = S \cdot a$$

T is determined from outside (input-variable)

The differential equations describe the change over time:

- The change in population (dp/dt) equals the birth-rate (b) minus the death rate (d) and is proportional to the current population (p):

$$dp/dt = p \cdot (b-d)$$

- The change in concentration of sugar (ds/dt) multiplied by the Volume (V) equals the negative consumption rate (f) of sugar :

$$V \cdot ds/dt = -f$$

or

$$ds/dt = -f/ V$$

The differential equations are:

$$dp/dt = p \cdot (b-d)$$

$$ds/dt = -f/V$$

Let us plug in the algebraic equations:

$$dp/dt = p \cdot (b-d)$$

$$ds/dt = -f/V$$

Let us plug in the algebraic equations:

$$dp/dt = p \cdot (b-d)$$

$$dp/dt = p \cdot (R \cdot s - S \cdot a)$$

$$ds/dt = -f/V$$

Let us plug in the algebraic equations:

$$dp/dt = p \cdot (b-d)$$

$$dp/dt = p \cdot (R \cdot s - S \cdot a)$$

$$dp/dt = p \cdot (R \cdot s - S \cdot (s_0 - s))$$

$$ds/dt = -f/V$$

Let us plug in the algebraic equations:

$$dp/dt = p \cdot (b-d)$$

$$dp/dt = p \cdot (R \cdot s - S \cdot a)$$

$$dp/dt = p \cdot (R \cdot s - S \cdot (s_0 - s))$$

$$\underline{dp/dt = p \cdot ((R+S) \cdot s - S \cdot s_0)}$$

$$ds/dt = -f/V$$

Let us plug in the algebraic equations:

$$dp/dt = p \cdot (b-d)$$

$$dp/dt = p \cdot (R \cdot s - S \cdot a)$$

$$dp/dt = p \cdot (R \cdot s - S \cdot (s_0 - s))$$

$$\underline{dp/dt = p \cdot ((R+S) \cdot s - S \cdot s_0)}$$

$$ds/dt = -f/V$$

$$\underline{ds/dt = -s \cdot p \cdot C_f \cdot (T/T_{ref}) \cdot 1/V}$$

Let us plug in the algebraic equations:

$$\underline{dp/dt = p \cdot ((R+S) \cdot s - S \cdot s_0)}$$

$$\underline{ds/dt = -s \cdot p \cdot C_f \cdot (T/T_{\text{ref}}) \cdot 1/V}$$

- Let us discretize the advance of time by the quantum h :
- Given x_t , we can compute x_{t+h} by using the Taylor-series expansion:

$$x_{t+h} = x_t + (dx/dt)_t \cdot h + (dx/dt^2)_t \cdot (h^2/2) + (dx/dt^3)_t \cdot (h^3/6) + \dots$$

- Let us drop all higher derivatives. We get:

$$x_{t+h} = x_t + (dx/dt)_t \cdot h$$

- This discretization scheme is called: **Forward Euler**

Let us apply Forward Euler to our differential equations:

$$p_{t+h} = p_t + (dp/dt)_t \cdot h$$

with

$$(dp/dt)_t = p_t \cdot ((R+S) \cdot s_t - S \cdot s_0)$$

$$s_{t+h} = s_t + (ds/dt)_t \cdot h$$

with

$$(ds/dt)_t = -s_t \cdot p_t \cdot C_f \cdot (T_t/T_{ref}) \cdot 1/V$$

- These four explicit equations are used to perform a simulation:

$$p_{t+h} = p_t + (dp/dt)_t \cdot h \text{ with } (dp/dt)_t = p_t \cdot ((R+S) \cdot s_t - S \cdot s_0)$$

$$s_{t+h} = s_t + (ds/dt)_t \cdot h \text{ with } (ds/dt)_t = -s_t \cdot p_t \cdot C_f \cdot (T_t/T_{ref}) \cdot 1/V$$

- We can simply punch them into a Python3 script:

```
while time < 10:
    dp_dt = p*((R+S)*s - S*s0)
    ds_dt = -s*p*C_f*(T/T_ref)*1/V
    p += h*dp_dt
    s += h*ds_dt
    a = s0-s
    time += h
    print(time, "\t", p, "\t", s, "\t", a)
```

- Here, there are computed within a loop. Each iteration represents one time-step: an advance of h in time.

This is the complete Python3-Script:

```
#!/usr/bin/env python3

#Setting the parameters
V = 1 #volume of fermentation vessel
s0 = 0.2 #initial concentration of sugar
p0 = 1e-6 #initial population of yeast [m3]
C_f = 50 #feeding Coefficient [1/day]
R = 10 #reproductivity [1/day]
S = 15 #sensitivity w.r.t. alcohol [1/day]
T_ref = 300 #reference temperature [K]
h = 0.01 #time-step of forward Euler integration

#Setting the initial values
p = p0
s = s0
a = s0 - s;
time = 0
```

```
#Setting the input-value
T = 310

#perform time-integration
while time < 10:
    dp_dt = p*((R+S)*s - S*s0)
    ds_dt = -s*p*C_f*(T/T_ref)*1/V
    p += h*dp_dt
    s += h*ds_dt
    a = s0-s
    time += h
    print(time, "\t", p, "\t", s, "\t", a)
```

- And this is the result for the yeast population:

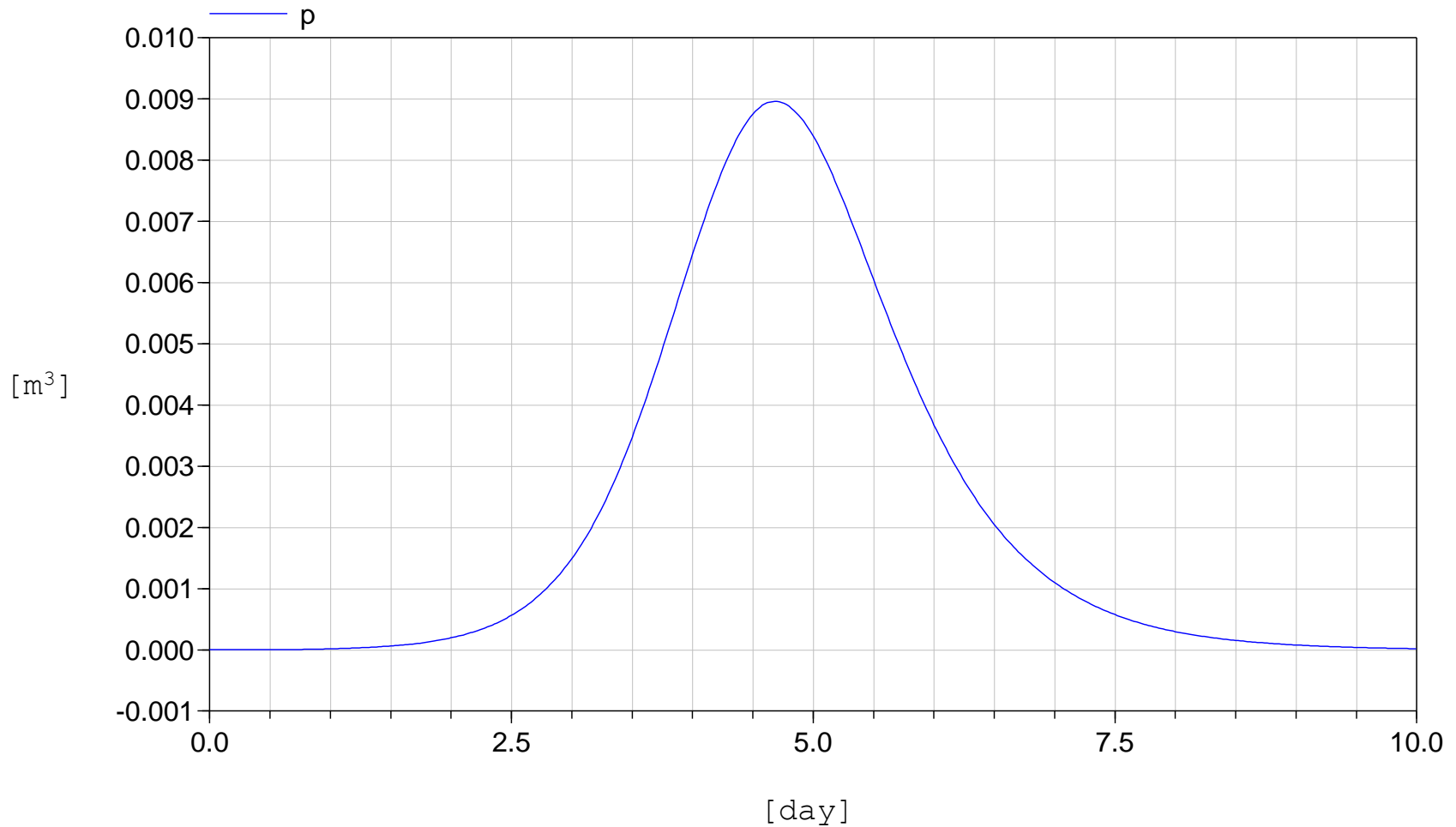

- Concentration of sugar and alcohol:

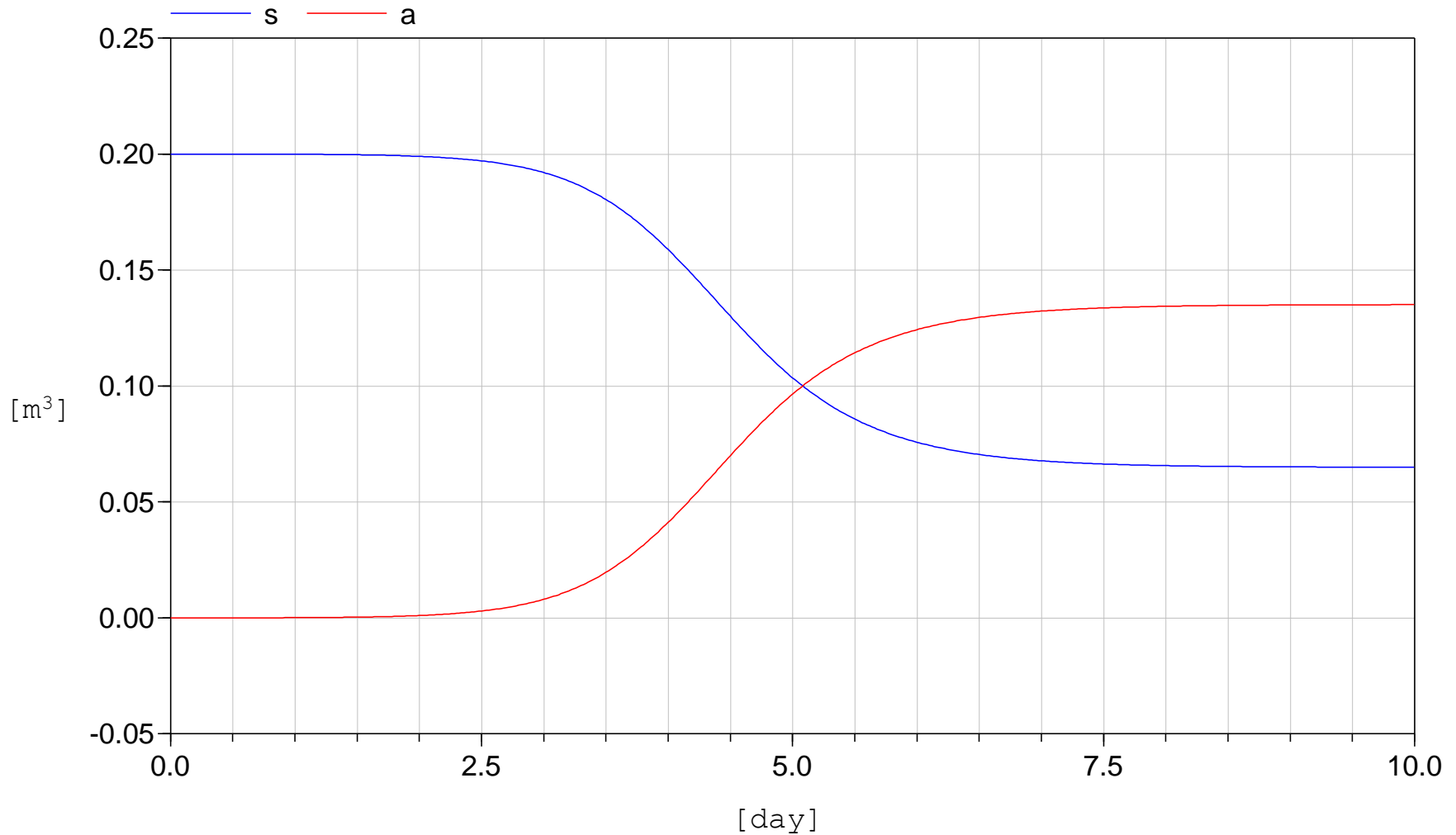

Interpretation of the simulation results:

- The population of yeast first grows exponentially. There seems to be an endless supply of sugar available.
- Then the population has reached a critical level and the concentration of sugar and alcohol are rapidly changing.
- Then, there is a sudden die-off due to the combination of starvation and self-poisoning.

Let us look at the computational structure of our model. We can classify our variables into vectors of...

- Input Variables: $\mathbf{u} = (T)$
- State Variables: $\mathbf{x} = (p, s)$
- State Derivatives: $d\mathbf{x}/dt = (dp/dt, ds/dt)$
- Output Variables: $\mathbf{y} = (a)$

- The system was then transformed into two functions:

$$\begin{aligned}d\mathbf{x}/dt &= f(\mathbf{x}, \mathbf{u}, t) \\ \mathbf{y} &= g(\mathbf{x}, \mathbf{u}, t)\end{aligned}$$

- This specific form is called: **state-space form**

State-Space Form

- We form a row vector out of \mathbf{x}, \mathbf{u} , and t : (p, s, T, t)
- We form a column vector out of $d\mathbf{x}/dt$ and \mathbf{y} : $(dp/dx, ds/dx, a)$
- Now we can represent the dependences of our computational structure by a Boolean incidence matrix.

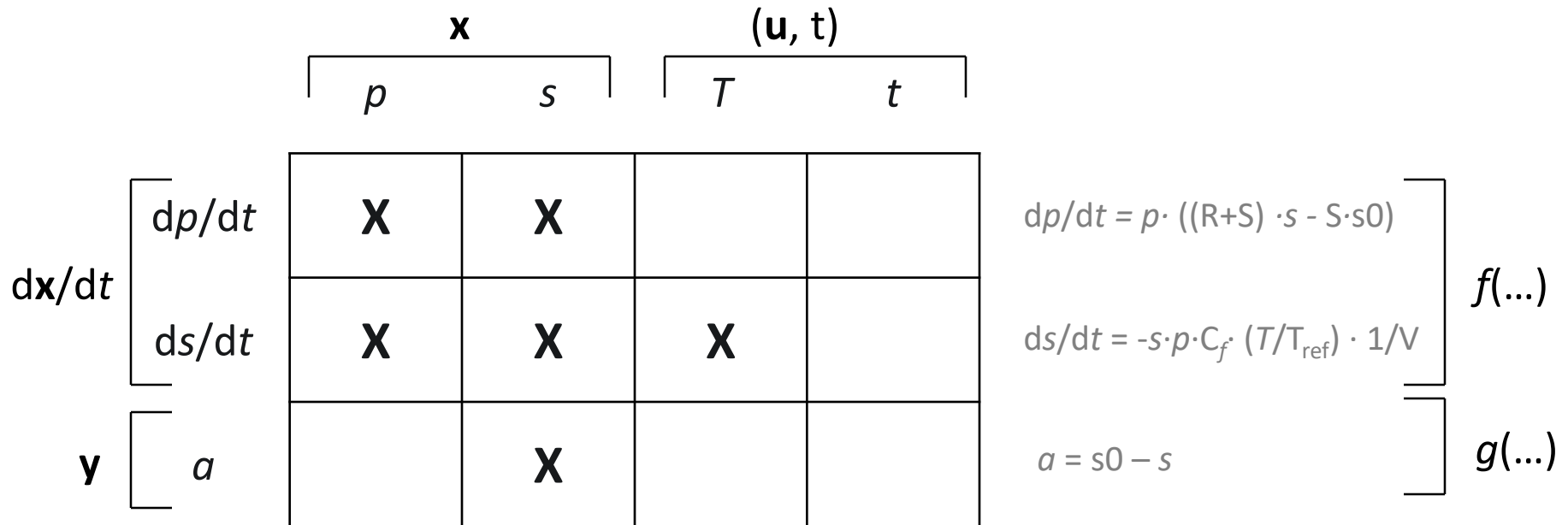

- The incidence matrix can be decomposed into four blocks: **A**, **B**, **C**, **D**.
- If $g(\dots)$ and $f(\dots)$ represent linear functions (not the case here!), the system can indeed be expressed by real-valued matrices:

$$\frac{dx}{dt} = \mathbf{A}x + \mathbf{B}(u, t)$$

$$y = \mathbf{C}x + \mathbf{D}(u, t)$$

	p	s	T	t
dp/dt	X	X		
ds/dt	X	X	X	
a		X		

The table illustrates the decomposition of the incidence matrix into four blocks: **A** (red), **B** (light blue), **C** (light green), and **D** (grey). The rows represent the derivatives of variables p , s , and a , and the columns represent the variables p , s , T , and t . The 'X' marks indicate non-zero entries in the matrix.

Let us summarize the development process of our simulation:

- First, we had to analyze our model and select the variables of interest.
- Then, we formulated a set of *differential-algebraic equations* (DAEs).
- Next, we had to transform this set of expressions into a computable/solvable form (*state-space form*).
- Finally, a time-discretization scheme was applied and a numerical integration could be performed (*numerical ODE-solver*).

Even for this small and rather trivial example, this development process was rather laborious.

- Larger models cause much more work.
- Also there are more complicated models that are difficult to transform into state-space form.
- If we change the model, the complete process has to be redone.
- Programming a simulation manually turns out to be very inconvenient and is also very error-prone.
- For these reasons, a number of computer languages have been developed that aim to automate this process.
- Let us take a look back in history...

- The language MIMIC was developed mainly for the Control Data super-computers in 1964.
- The listing presents the MIMIC code for the simulation of a swinging pendulum.
- Successors of these language were CSMP and ACSL. They prevailed up to the 80s.

```
CON (G)           Declaration of constants
PAR (1X0 , X0)    Declaration of parameters
DT 0.05           Definition of time step

1X INT (-G*Z, 1X0) Integration
X INT (1X, X0)
Y 1. -COS (X)     Equation for y position
Z SIN (X)         Equation for z position

FIN (T, 4.9)      Command for integration

PLO (T, X, Y, Z)  Commands for plotting
ZER (0., -5, 0., -1)
SCA (5., 5., 2., 1.)

END End of program
```

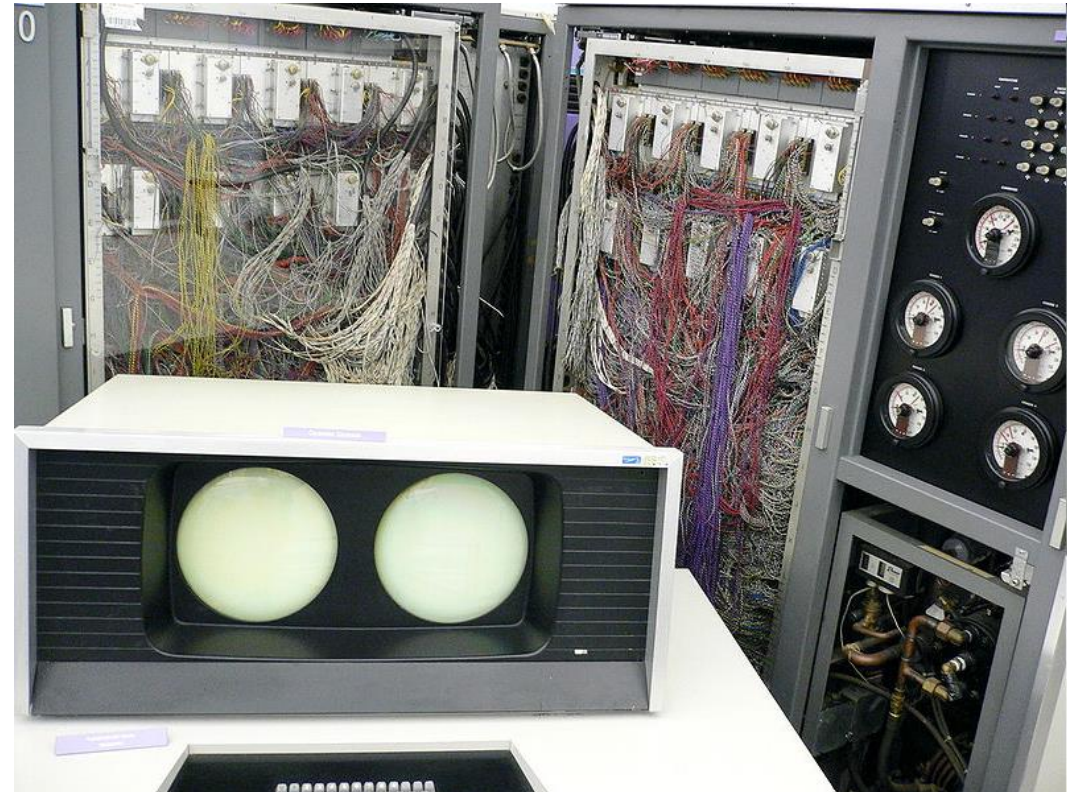

CDC 6600

- 40 MHz, roughly 1MFLOPS, 64K 60-bit words of memory
- Roughly 400'000 transistors, over 100 miles of wiring
- A predecessor of the RISC-Architecture. Developed by Seymour Cray
- Prize: 7 – 10 Million \$ (and by that time, the dollar was worth something)

- The model could be formulated by assignments and integrators.
- These model “equations” could be arbitrarily ordered.
- The appropriate order for the state-space form is automatically derived.
- The time-discretization is not part of the model anymore. Different numerical ODE-solvers can be applied (better than FE)

```
CON (G)           Declaration of constants
PAR (1X0, X0)    Declaration of parameters
DT 0.05          Definition of time step

1X INT (-G*Z, 1X0) Integration
X INT (1X, X0)
Y 1. -COS (X)    Equation for y position
Z SIN (X)        Equation for z position

FIN (T, 4.9)     Command for integration

PLO (T, X, Y, Z) Commands for plotting
ZER (0., -5, 0., -1)
SCA (5., 5., 2., 1.)

END End of program
```

- MIMIC could not handle real equations, only causal assignments.
- There were hardly any means to structure the program. The language was almost completely flat and there is only one global namespace.

```
CON (G)           Declaration of constants
PAR (1X0, X0)     Declaration of parameters
DT 0.05           Definition of time step

1X INT (-G*Z, 1X0) Integration
X INT (1X, X0)
Y 1. -COS (X)     Equation for y position
Z SIN (X)         Equation for z position

FIN (T, 4.9)      Command for integration

PLO (T, X, Y, Z)  Commands for plotting
ZER (0., -5, 0., -1)
SCA (5., 5., 2., 1.)

END End of program
```

- The **Dynamic Modeling Language** was developed by Hilding Elmquist in 1978.
- The listing on the left displays the code of an assembled electric circuit and of its capacitor component.

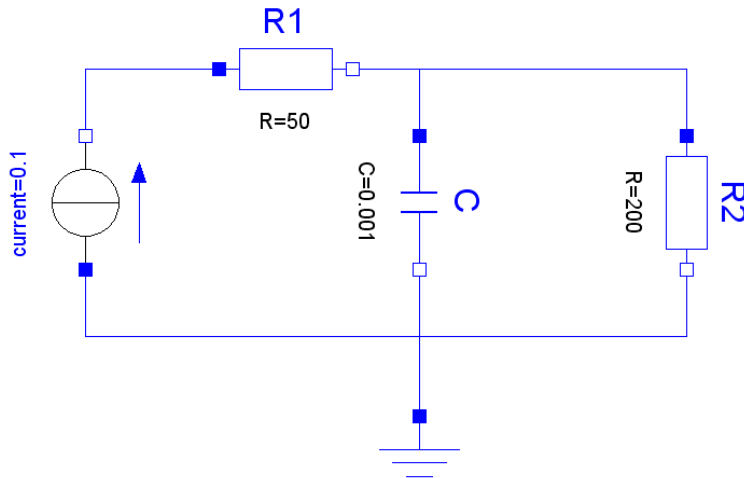

```
model type capacitor
  cut A (Va / I) B (Vb / -I)
  main cut C [A B]
  main path P <A - B>
  local V
  parameter C
  V = Va -Vb
  C*der(V) = I
end

model Network
  submodel ( resistor ) R1 R2
  submodel ( capacitor ) C
  submodel ( current ) F
  submodel Common
  input i
  output y
  connect Common to F to R1 to (C par R2)
    to Common
  E.I = i
  y = R2.Va
end
```

- Dymola is a **declarative** language. It only contains code for the model-equations. The simulation is completely decoupled from the model description.
- This language enabled the formulation of hierarchic elements such as sub-components.
- These components could be automatically connected.

```
model type capacitor
  cut A (Va / I) B (Vb / -I)
  main cut C [A B]
  main path P <A - B>
  local V
  parameter C
  V = Va - Vb
  C*der(V) = I
end

model Network
  submodel ( resistor ) R1 R2
  submodel ( capacitor ) C
  submodel ( current ) F
  submodel Common
  input i
  output y
  connect Common to F to R1 to (C par R2)
    to Common
  E.I = i
  y = R2.Va
end
```

- Dymola can handle non-causal equations such as $u = R \cdot i$

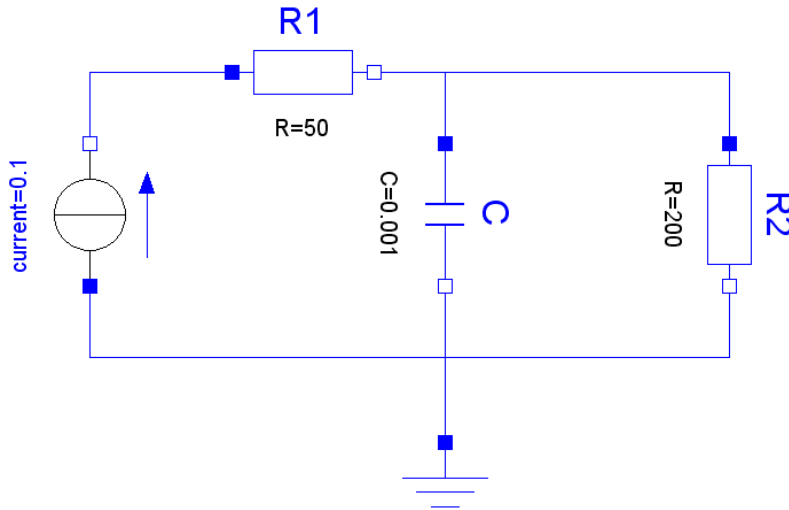

- In R1, the causality is: $u := R \cdot i$
- In R2, the causality is: $i := u/R$
- In Dymola, one can use the same, non-causal equations for both resistor components.

```

model type capacitor
  cut A (Va / I) B (Vb / -I)
  main cut C [A B]
  main path P <A - B>
  local V
  parameter C
  V = Va - Vb
  C*der(V) = I
end

model Network
  submodel ( resistor ) R1 R2
  submodel ( capacitor ) C
  submodel ( current ) F
  submodel Common
  input i
  output y
  connect Common to F to R1 to (C par R2)
    to Common
  E.I = i
  y = R2.Va
end
    
```

- *Dymola* never had any real impact in industry, it remained within academia.
- There, its main ideas were preserved and extended by *Omola*. This language enables a truly object-oriented modeling, featuring inheritance, wrapping etc.
- Modeling in *Omola* was also performed graphically. Only the fundamental equations are entered in textual form. All higher-level model are assembled graphically.
- Also *Omola* remained within academia. Things started to change as *Modelica* was born in 1997.

Demonstration

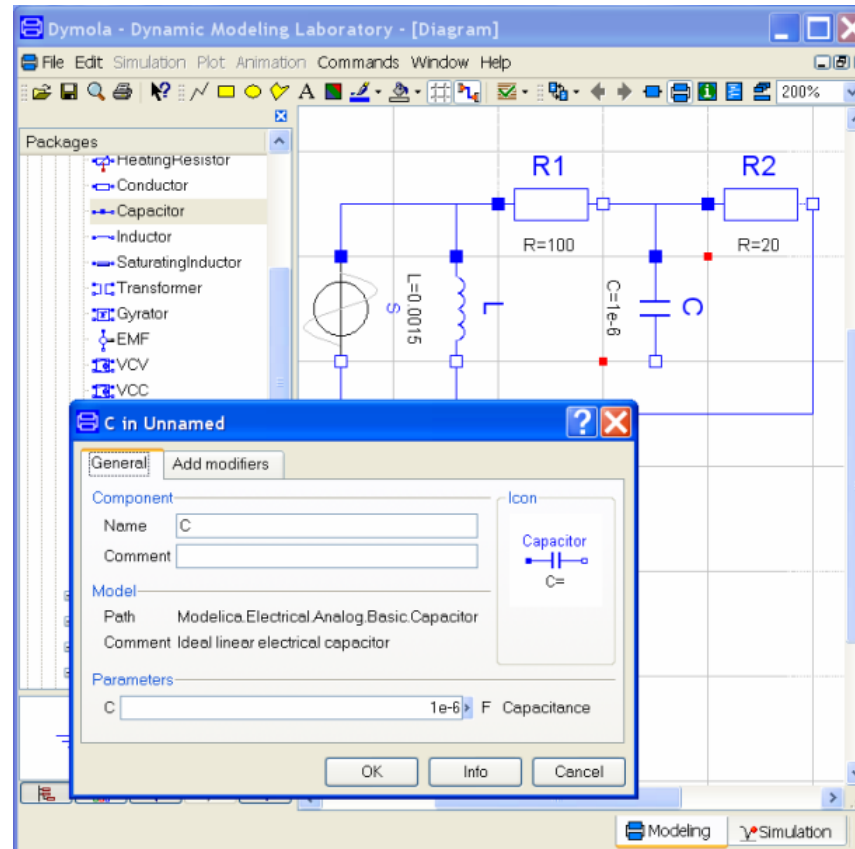

- As you see: Dymola is still alive, but not as modeling language but as an M&S environment for Modelica.
- In Modelica, we can directly punch in our model equations.
- There is no need anymore to derive the state-space form by paper and pencil.

model Yeast

```
parameter Real V = 1 "volume of fermentation vessel";  
parameter Real s0 = 0.2 "initial concentration of sugar";  
parameter Real p0 = 1e-6 "initial population of yeast";  
parameter Real C_f = 50 "Feeding Coefficient [1/day]";  
parameter Real R = 10 "Reproductivity [1/day]";  
parameter Real S = 15 "Sensitivity w.r.t. alcohol [1/day]";  
parameter Real T_ref = 300 "reference temperature";  
Real p "population of yeast";  
Real b "birth rate";  
Real d "death rate";  
Real s "concentration of sugar";  
Real a "concentration of alcohol";  
Real f "consumption of sugar (feeding)";  
Real T "current temperature";
```

initial equation

```
p = p0;  
s = s0;
```

equation

```
f = s * p * C_f * (T/T_ref);  
a = s0 - s;  
b = R * s;  
d = S * a;  
T = 310;  
der(p) = p*(b-d);  
V*der(s) = -f;  
end Yeast;
```

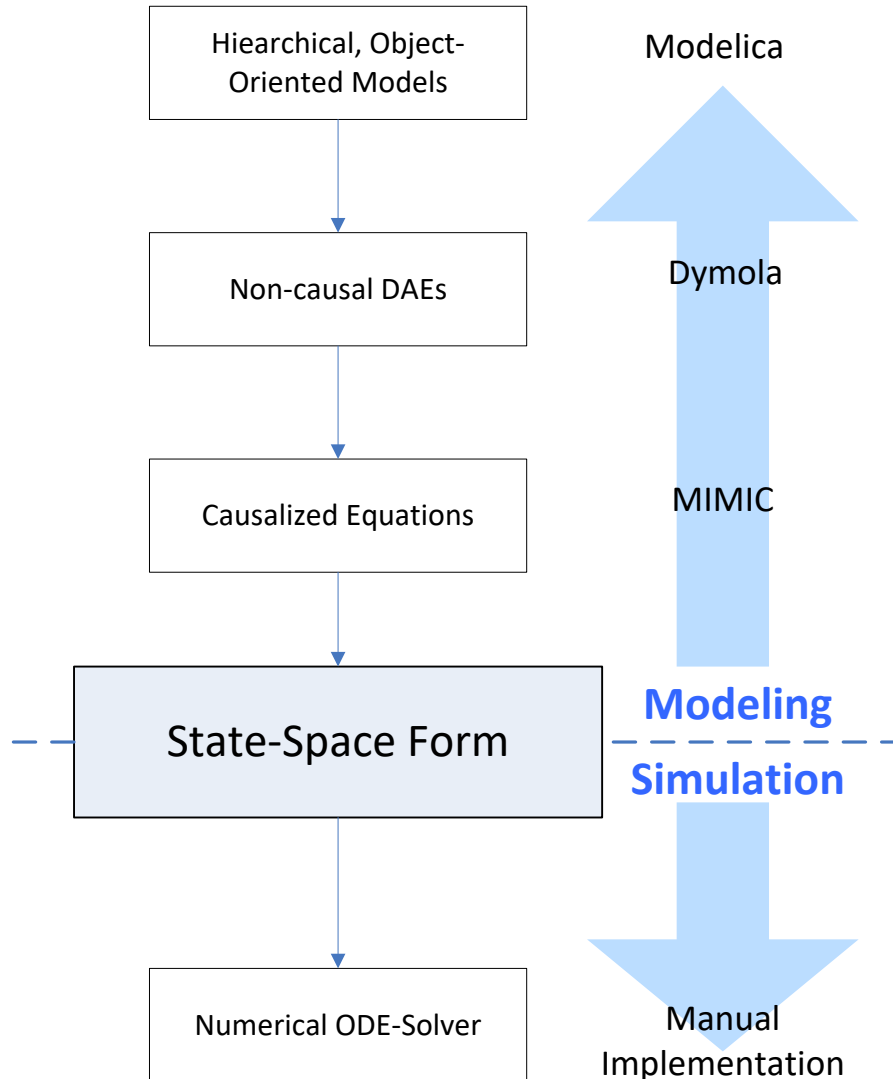

- In the field of programming languages, there are high-level languages (Python, C++) and low-level languages (Assembler)
- The same is true for modeling languages.
- The state-space form is a common target of their compilation scheme (the Assembler language of a modeler).

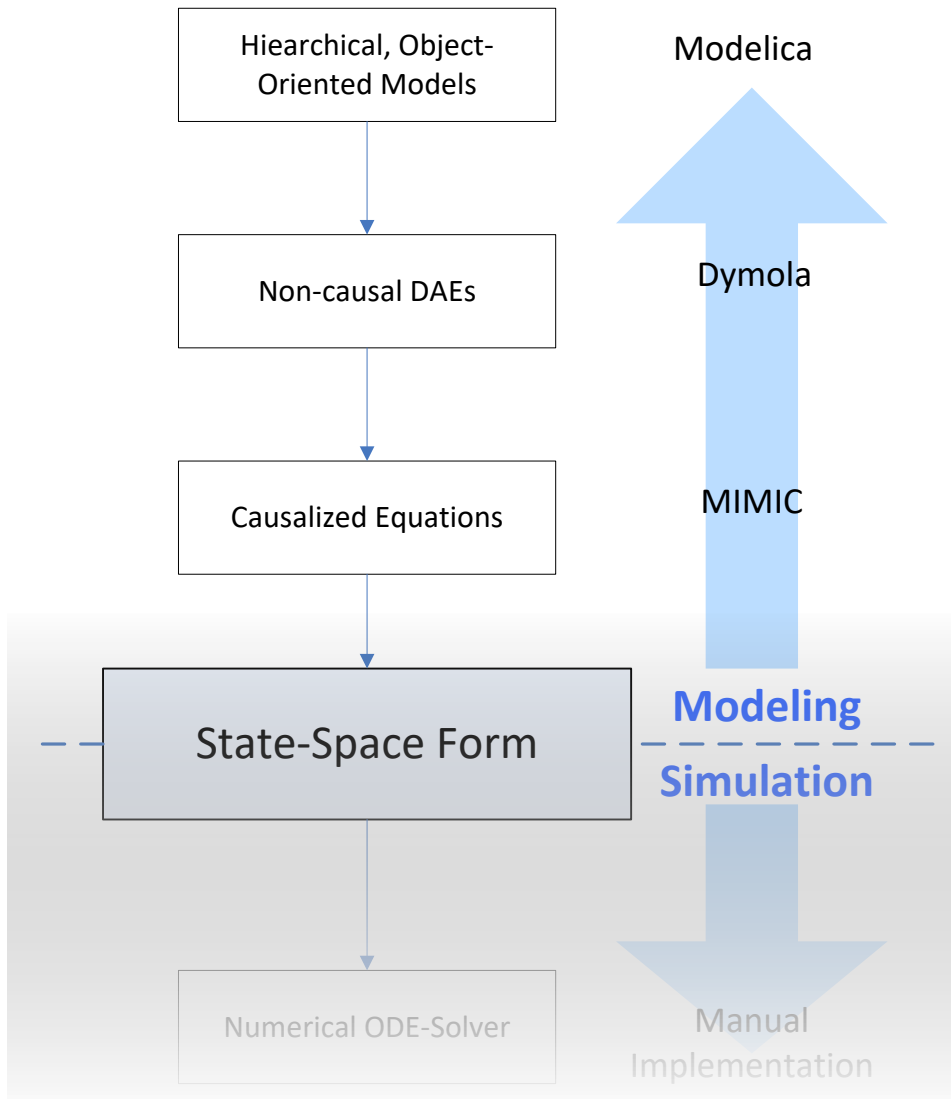

- The first (and larger) part of the lecture concerns the modeling side.
- You will learn to model in Modelica using the software Dymola.

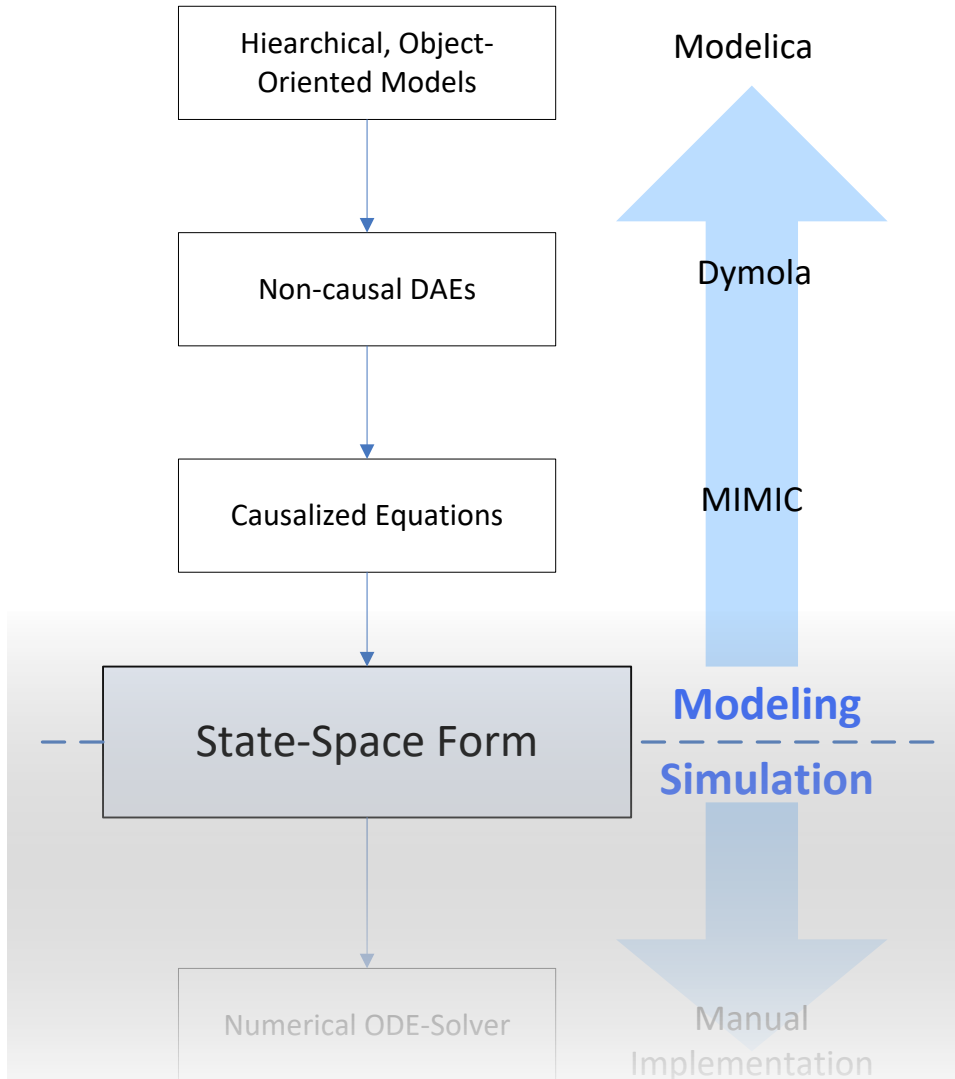

The way up:



- To this end, we have to learn how to formulate the laws of physics in an object-oriented way.

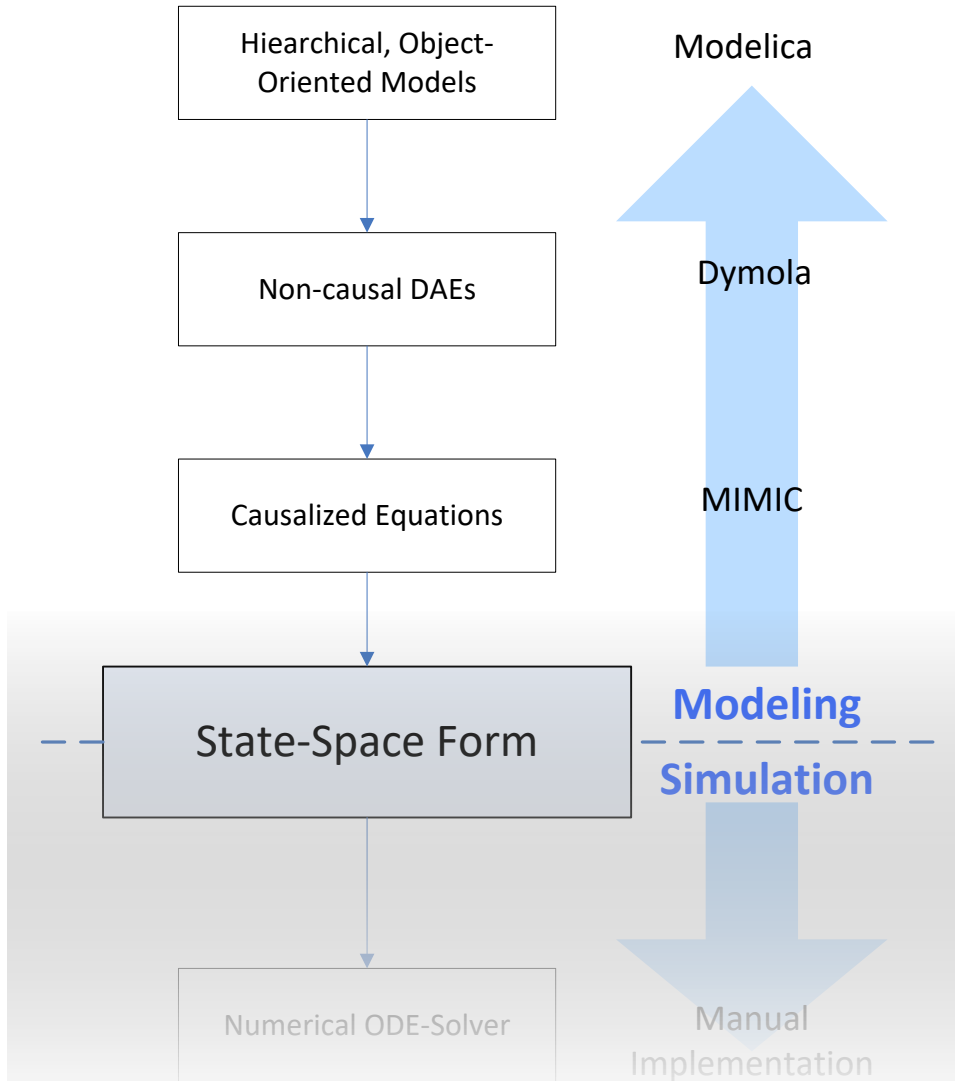

The way up:



- To this end, we have to learn how to formulate the laws of physics in an object-oriented way.
- This is a sole matter of physics. It has nothing to do with computer science.

- The way down: 
- Then we have to learn how the languages are compiled, and how the state-space form is automatically derived.

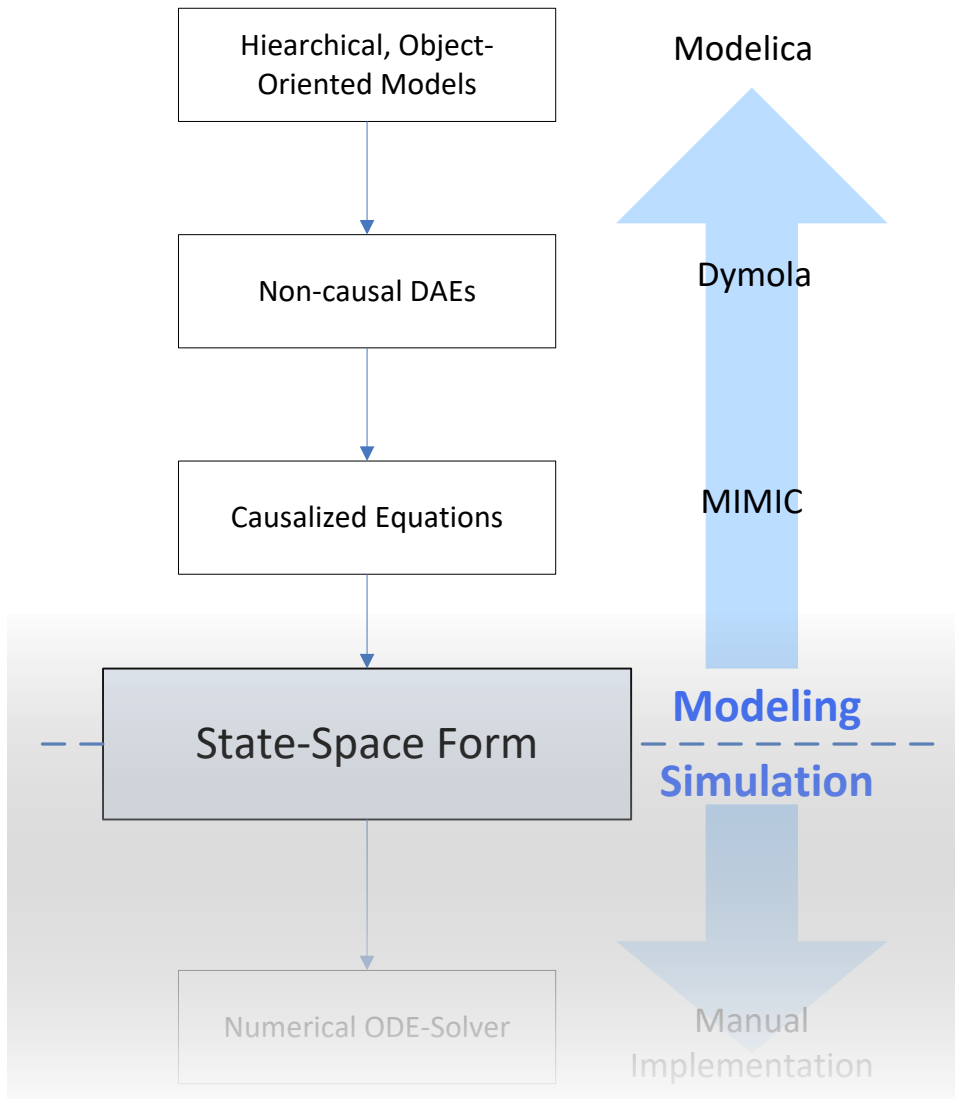

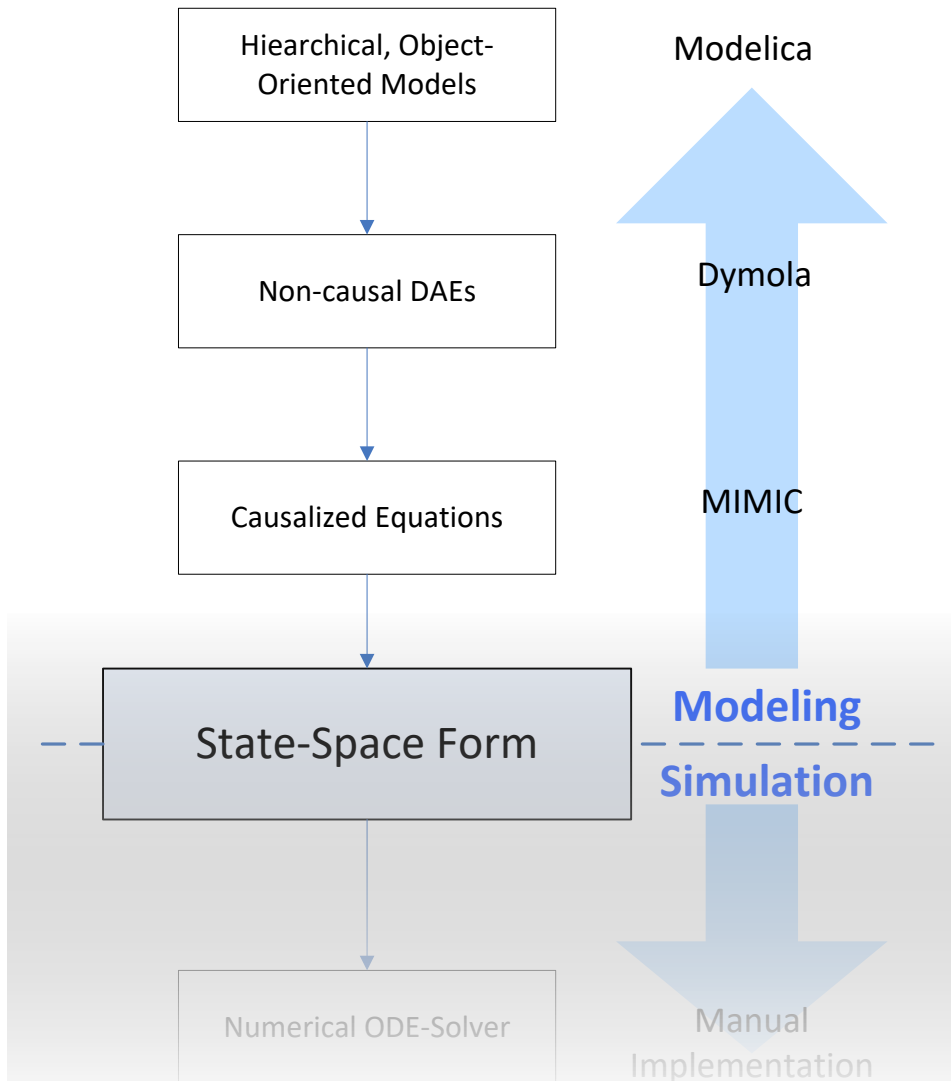

The way down: 

- Then we have to learn how the languages are compiled, and how the state-space form is automatically derived.
- This is a sole matter of computer science. It has nothing to do with physics.

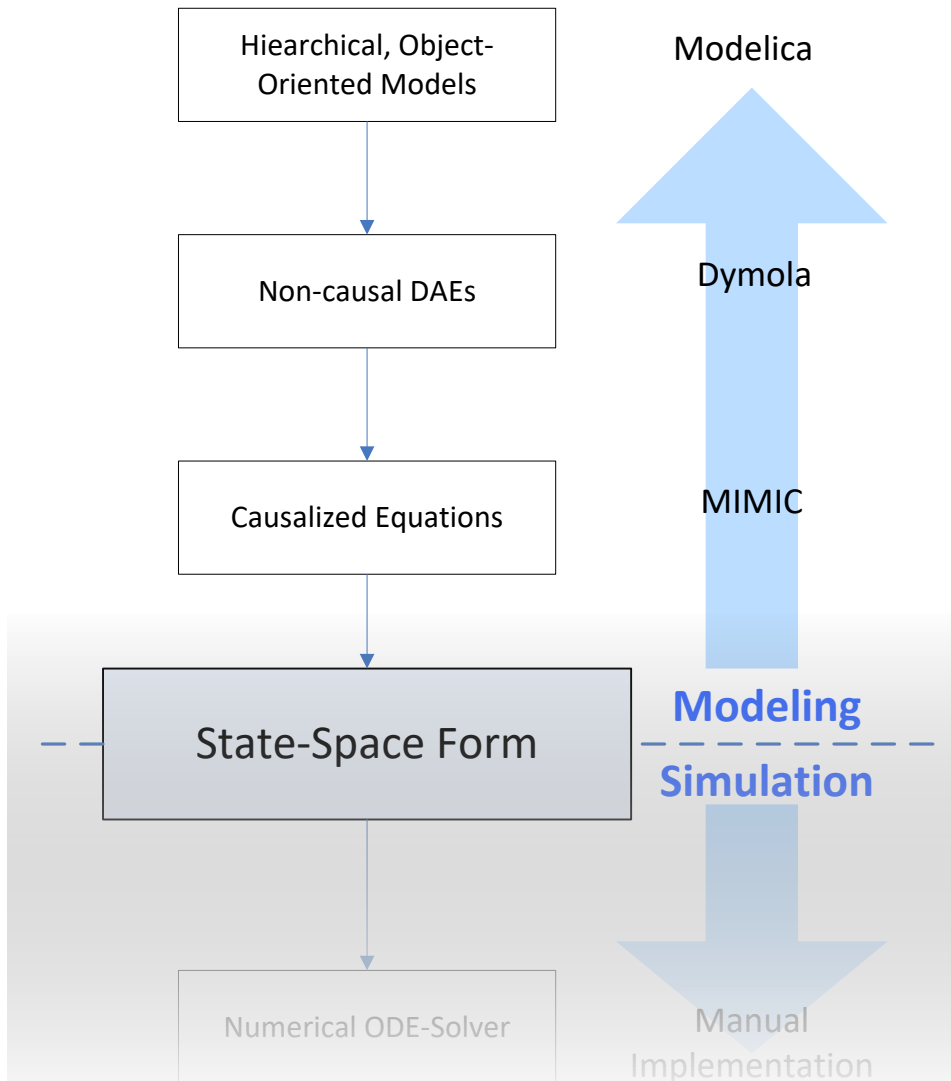

- The way down: 
- Then we have to learn how the languages are compiled, and how the state-space form is automatically derived.
 - This is a sole matter of computer science. It has nothing to do with physics.
 - (And by the way, we are going to model a lot of cool systems...)

- The second (and smaller) part of this lecture series concerns simulation.
- You will learn different techniques how to implement numerical ODE solvers, and how they influence the simulation result.
- In addition, the handling of events will be discussed.

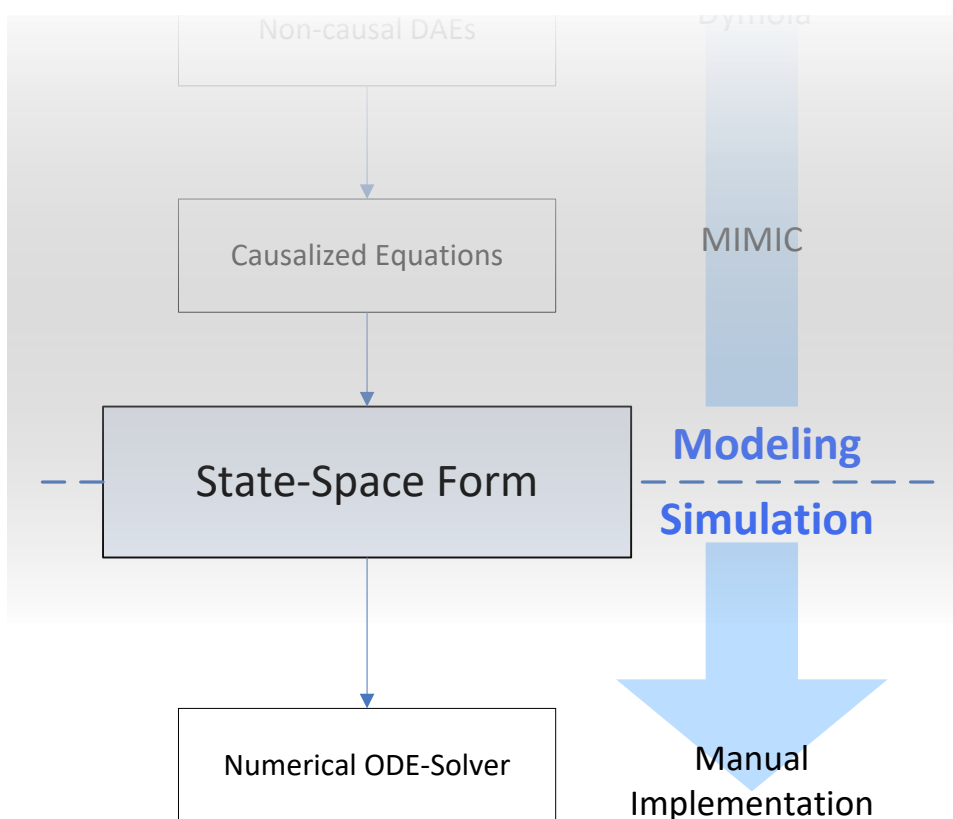

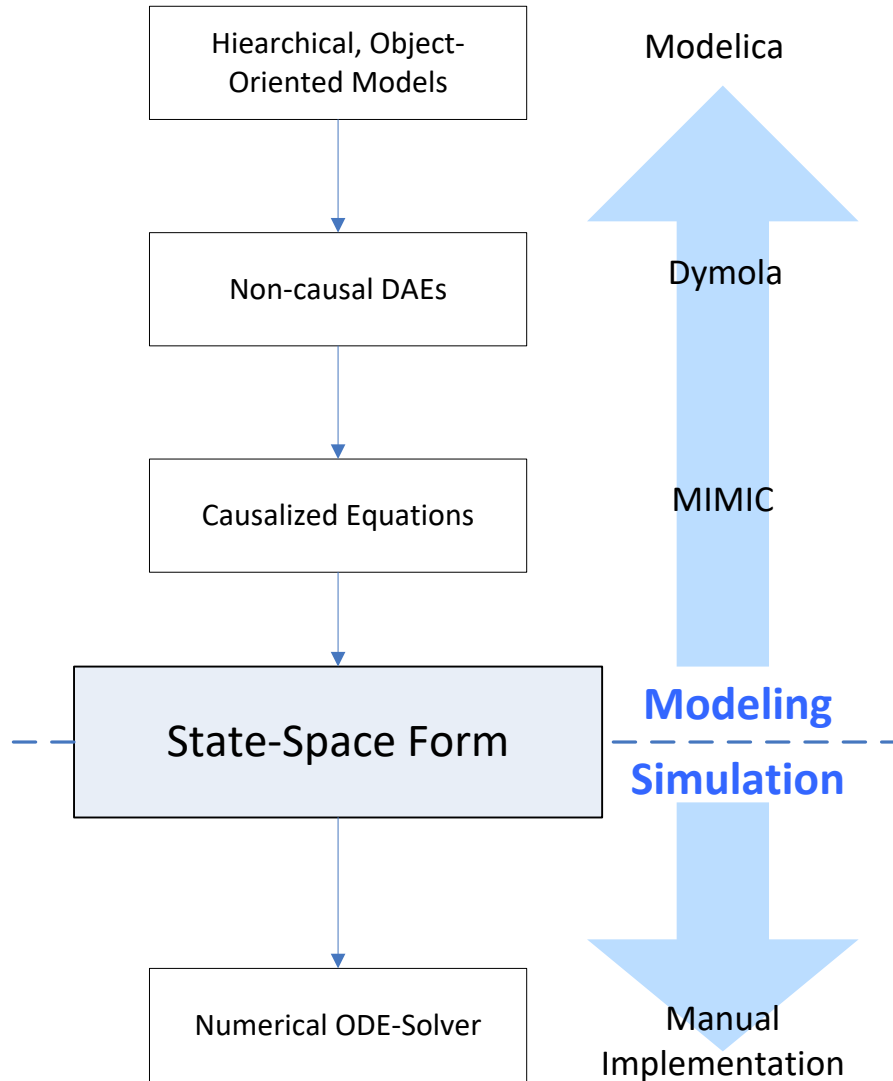

System Engineering

Model-based Safety Analysis

Requirements Modeling

Integration of Data and Tools

Early Design Optimization

System Dynamics Model

Control Design

Cyber-Physical Systems

Model-Based Algorithms: e.g. Health Monitoring

Embedded Models

Certified, Distributed Model Code

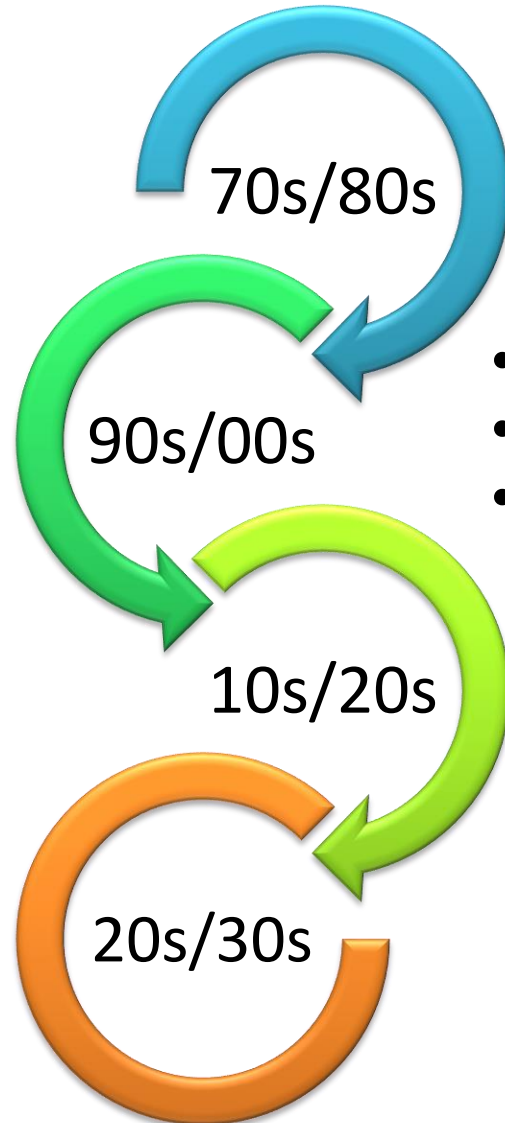

- **Focus on Simulation**
 - ODE-based
 - Numerical Solvers
- **Focus on Modeling**
 - DAE-based
 - Model Compiler Technology
- **Focus on Tool-Integration**
 - Based on Interfaces (FMI)
 - Model-based System Engineering
- **Focus on Autonomous Modelling**
 - Free online modelling
 - AI-based modelling

Questions?